

ATR FIRST GENERATION



ATR

42-300/-320



Since its introduction into service in December 1985, the ATR 42 has become a reference in the regional air transport industry for reliability and profitability. Remarkably simple to operate and maintain, equipped with efficient, low-fuel-burn engines, the ATR 42 operating costs are 15%–20% lower than the competition.

The basic ATR 42-300 is fitted with two PW120 engines rated at 2,000 shp each. The ATR 42-320, fitted with two PW121 engines rated at 2,100 shp each, has been developed to offer increased performance for hot and high conditions and short runway operations. About 400 first generation ATR 42 have been ordered by airlines worldwide, contributing to their development and continuous profitability.

MATCHING CUSTOMER NEEDS

An Alenia Aeronautica and EADS joint venture

ATR

PROPELLING TOMORROW'S WORLD

ATR 42-300/-320

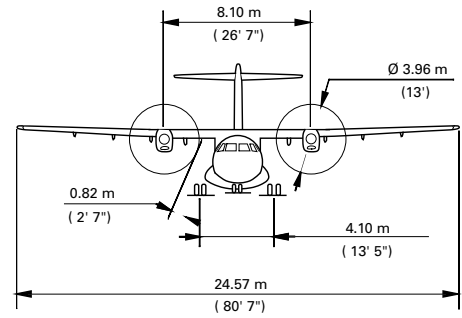
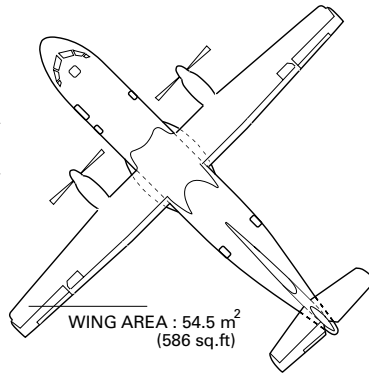
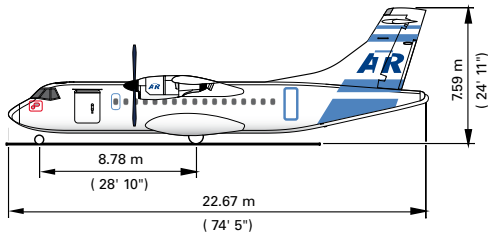

STANDARD CONFIGURATION

48 seats at 30" pitch

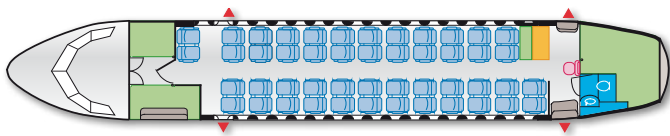

Attendant seat Galley Toilet Baggage Emergency exit

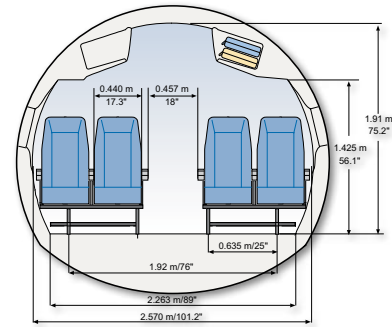

ENGINES	ATR 42-300	ATR 42-320
PRATT & WHITNEY CANADA	PW120	PW121
Take-off power	1,800 SHP	1,900 SHP
Take-off power - One engine	2,000 SHP	2,100 SHP
Max continuous	1,700 SHP	1,900 SHP
Max climb	1,700 SHP	1,700 SHP
Max cruise	1,619 SHP	1,700 SHP
PROPELLERS		
Hamilton Standard	14 SF-5	14 SF-5
Blades: 4; Diameter: 39.6 m - 13 ft		
WEIGHTS		
Max take-off weight (basic)	16,700 kg - 36,807 lb	
Max take-off weight (option)	16,900 kg - 37,257 lb	
Max landing weight (basic)	16,400 kg - 36,146 lb	
Max zero fuel weight (basic)	15,200 kg - 33,501 lb	
Max zero fuel weight (option)	15,540 kg - 34,259 lb	
Operational empty weight (Tech. Spec.)	10,290 kg - 22,679 lb	
Operational empty weight (Typical in-service)	10,900 kg - 24,030 lb	
Max payload (at typical in-service OEW)	4,300 kg - 9,477 lb	
Max fuel load	4,500 kg - 9,921 lb	

NB: en-route performance computed assuming Max Optional TOW, Typical in-service OEW, 48 PAX@95 Kg, JAR fuel reserves, taxi time allowance: 4 min.

AIRFIELD PERFORMANCE	ATR 42-300	ATR 42-320
TAKE-OFF DISTANCE		
• Basic (MTOW - ISA - SL)	1,090 m - 3,576 ft	1,041 m - 3,415 ft
• At TOW for 300 Nm Max pax - SL - ISA	1,073 m - 3,520 ft	1,026 m - 3,366 ft
• At TOW for 300 Nm Max pax - 3,000 ft - ISA + 10	1,271 m - 4,170 ft	1,222 m - 4,009 ft
TAKE-OFF SPEED (V2 min @ MTOW)	108 KCAS	108 KCAS
LANDING FIELD LENGTH (JAR25)		
• Basic (MLW - SL)	886 m - 2,907 ft	
• At LW (max pax + reserves) - SL	864 m - 2,835 ft	
• Reference speed at landing	103 KIAS	103 KIAS
EN-ROUTE PERFORMANCE		
Optimum climb speed	160 KCAS	160 KCAS
Rate of climb (ISA, SL, MTOW)	1,320 ft/min	1,320 ft/min
Time to climb to FL170	15.1 min	14.8 min
One engine net ceiling (95% MTOW, ISA +10)	9,580 ft	10,940 ft
Max Cruise speed (95% MTOW - ISA - Optimum FL)	266 KTAS - 493 km/h	270 KTAS - 500 km/h
Fuel flow at cruise speed	568 kg/h 1,252 lb/h	584 kg/h 1,287 lb/h
Range with max pax	456 Nm	459 Nm
200 Nm Block Fuel	490 kg - 1,081 lb	491 kg - 1,083 lb
CO2 Emission	1,544 kg - 3,403 lb	1,547 kg - 3,410 lb
300 Nm Block Fuel	669 kg - 1,475 lb	668 kg - 1,473 lb
CO2 Emission	2,108 kg - 4,648 lb	2,105 kg - 4,639 lb

ATR FIRST GENERATION

ATR

72-200/-210



The ATR 72 is derived from the ATR 42 with a 4.5 m stretched fuselage. The two aircraft feature a high degree of commonality: the same cross section, the same cockpit for cross-crew qualification. Offering a standard capacity of 66 seats, the ATR 72-200 is equipped with two PW124B engines, rated at 2,400 SHP each. The derivative version of the basic ATR 72, the ATR 72-210 is equipped with two higher power 2,750 SHP PW127 engines.

Main characteristics of the -210 version are excellent "hot & high" and short field capabilities. It also features enhancements to cabin comfort particularly in terms of advanced internal noise treatment and superior cabin air conditioning. A leader in its market segment, the ATR 72 has won hundred orders worldwide and achieves an in-service dispatch reliability largely exceeding 99 %.

MATCHING CUSTOMER NEEDS

An Alenia Aeronautica and EADS joint venture

ATR

PROPELLING TOMORROW'S WORLD

ATR 72-200/-210

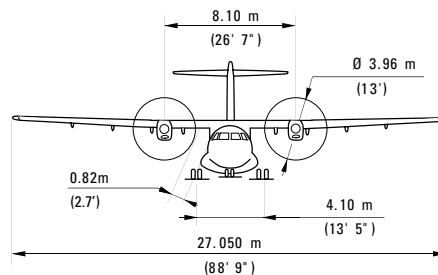
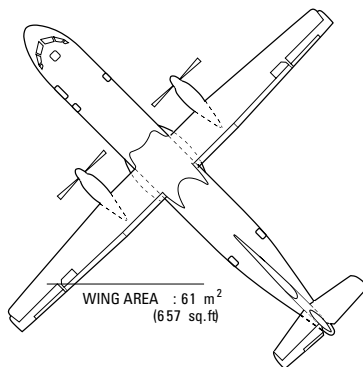
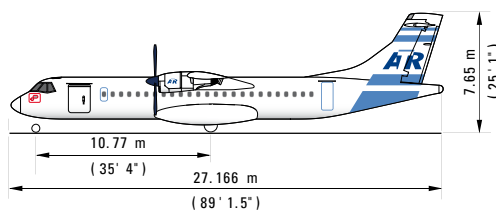

STANDARD CONFIGURATION

66 seats at 31" pitch

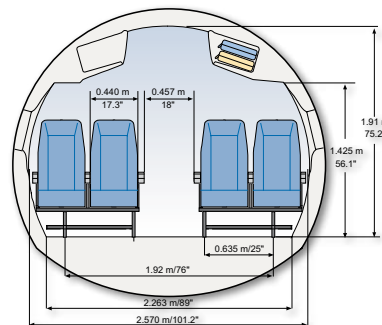
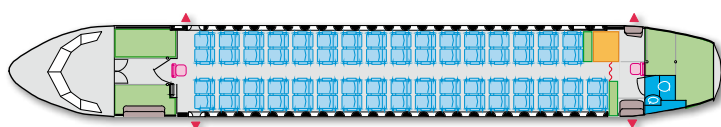

Attendant seat Galley Toilet Baggage Emergency exit

ENGINES	ATR 72-200	ATR 72-210
PRATT & WHITNEY CANADA	PW 124B	PW127
Take-off power	2,160 SHP	2,475 SHP
Take-off power - One engine	2,400 SHP	2,750 SHP
Max continuous	2,400 SHP	2,500 SHP
Max climb	2,088 SHP	2,192 SHP
Max cruise	2,088 SHP	2,132 SHP
PROPELLERS		
Hamilton Standard	14 SF-11	247F-1
Blades: 4; Diameter: 39.6 m - 13 ft		
WEIGHTS		
Max take-off weight (basic)	21,500 kg - 47,399 lb	
Max take-off weight (option)	22,000 kg - 48,501 lb	
Max landing weight	21,350 kg - 47,068 lb	
Max zero fuel weight (basic)	19,700 kg - 43,430 lb	
Max zero fuel weight (option)	20,000 kg - 44,092 lb	
Operational empty weight (Tech. Spec.)	12,400 kg - 27,337 lb	12,450 kg - 27,447 lb
Operational empty weight (Typical in-service)	13,000 kg - 28,660 lb	
Max payload (at typical in-service OEW)	7,000 kg - 15,432 lb	
Max fuel load	5,000 kg - 11,023 lb	

AIRFIELD PERFORMANCE	ATR 72-200	ATR 72-210
TAKE-OFF DISTANCE		
• Basic (MTOW - ISA - SL)	1,409 m - 4,623 ft	1,211 m - 3,973 ft
• Option (MTOW - ISA - SL)	1,506 m - 4,941 ft	1,291 m - 4,236 ft
• At TOW for 300 Nm Max pax - SL - ISA	1,251 m - 4,104 ft	1,106 m - 3,629 ft
• At TOW for 300 Nm Max pax - 3,000 ft - ISA +10	1,522 m - 4,993 ft	1,333 m - 4,373 ft
TAKE-OFF SPEED (V2 min @ MTOW)	115 KCAS	113 KCAS
LANDING FIELD LENGTH (JAR25)		
• Basic (MLW - SL)	1,035 m - 3,395 ft	902 m - 2,959 ft
• At LW (max pax + reserves) - SL	983 m - 3,225 ft	855 m - 2,805 ft
• Reference speed at landing	114 KIAS	109 KIAS
EN-ROUTE PERFORMANCE		
Optimum climb speed	170 KCAS	170 KCAS
One engine net ceiling (95% MTOW, ISA +10)	8,505 ft	10,000 ft
Max Cruise speed (95% MTOW - ISA - Optimum FL)	278 KTAS - 515 km/h	279 KTAS - 517 km/h
Fuel flow at cruise speed	720 kg/h - 1,587 lb/h	760 kg/h - 1,675 lb/h
Range with max pax	872 Nm	805 Nm
200 Nm Block Fuel	579 kg - 1,276 lb	609 kg - 1,342 lb
CO2 Emission	1,823 kg - 4,019 lb	1,918 kg - 4,228 lb
300 Nm Block Fuel	811 kg - 1,787 lb	845 kg - 1,862 lb
CO2 Emission	2,554 kg - 5,630 lb	2,661 kg - 5,866 lb

NB: en-route performance computed assuming Max Optional TOW, Typical in-service OEW, 66 PAX@95 Kg, JAR fuel reserves, taxi time allowance: 4 min.